

**MSZ-GS30NA2 & MUZ-GS30NA2**  
**30,000 BTU/H WALL-MOUNTED INDOOR UNIT**  
**30,000 BTU/H HEAT PUMP OUTDOOR UNIT**



Job Name:

System Reference:

Date:



Indoor Unit.....MSZ-GS30NA2

Outdoor Unit.....MUZ-GS30NA2

**INDOOR UNIT FEATURES**

- Dual Barrier Coating
- Slim wall-mounted indoor units provide zone comfort control
- The outdoor unit powers the indoor unit, and should a power outage occur, the system is automatically restarted when power returns
- Multiple fan speed options: Low, Medium, High, Super-high
  - Auto and Powerful modes available in addition to the four fan speeds
- Multiple control options available:
  - Back-lit screen handheld remote controller (provided with the unit)
  - kumo cloud® smart device app for remote access
  - Third-party interface options
  - Wired or wireless controllers
- Hot-Start Technology: no cold air rush at equipment startup or when restarting after defrost cycle
- Powerful Operation: quickly cools or heats the room by automatically adjusting fan speed and set temperature for 15 minutes
- Weekly Timer: easily set desired temperatures and operation ON/OFF times to match your lifestyle
- Smart Set: recalls a preferred preset temperature setting at the touch of a button
- Smart Dry Mode: improved moisture removal is achieved by optimizing the control of the indoor fan, compressor, and heat exchanger
- Wide Vane mode provides an airflow of 150° in heating and 100° in cooling
- Nano Platinum Filter: incorporates nanometer-sized platinum-ceramic particles that kill bacteria and deodorize air
- Anti-allergy Enzyme Filter: traps allergens such as molds and bacteria and decomposes them using enzymes

**OUTDOOR UNIT FEATURES**

- INVERTER-driven compressor and LEV provide high efficiency and comfort while using only the energy needed to maintain maximum performance
- Blue Fin anti-corrosion treatment applied to the outdoor unit heat exchanger for increased coil protection and longer life
  - Rated for 2,000 hours spraying time per ASTM B117 Standard

# SPECIFICATIONS: MSZ-GS30NA2 & MUZ-GS30NA2

Cooling at 95°F <sup>1</sup>	Maximum Capacity	BTU/H	30,600
	Rated Capacity	BTU/H	30,600
	Minimum Capacity	BTU/H	10,300
	Maximum Power Input	W	3,320
	Rated Power Input	W	3,320
	Moisture Removal	Pints/h	7.8
	Sensible Heat Factor		0.72
Heating at 47°F <sup>2</sup>	Maximum Capacity	BTU/H	32,600
	Rated Capacity	BTU/H	34,000
	Minimum Capacity	BTU/H	9,800
	Maximum Power Input	W	3,340
	Rated Power Input	W	3,580
	Power Factor [208V / 230V]	%	98.0 / 98.0
Heating at 17°F <sup>3</sup>	Maximum Capacity	BTU/H	20,800
	Rated Capacity	BTU/H	20,000
	Maximum Power Input	W	2,600
	Rated Power Input	W	2,500
Heating at 5°F <sup>4</sup>	Maximum Capacity	BTU/H	15,470
	Maximum Power Input	W	2,200
Heating at -4°F <sup>5</sup>	Maximum Capacity	BTU/H	11,500
Efficiency	SEER <sup>2</sup>		19.1
	EER <sup>2</sup> <sup>1</sup>		9.2
	HSPF <sup>2</sup> [IV]		8.9
	COP at 47°F <sup>2</sup>		2.78
	COP at 17°F at Maximum Capacity <sup>3</sup>		2.34
	COP at 5°F at Maximum Capacity <sup>4</sup>		2.06
	COP at -4°F at Maximum Capacity <sup>5</sup>		1.76
ENERGY STAR <sup>®</sup> Certified		No	
Electrical	Voltage, Phase, Frequency		208/230, 1, 60
	Guaranteed Voltage Range	V AC	187 - 253
	Voltage: Indoor - Outdoor, S1-S2	V AC	208/230
	Voltage: Indoor - Outdoor, S2-S3	V DC	24
	Short-circuit Current Rating [SCCR]	kA	5
	Recommended Fuse/Breaker Size (Outdoor)	A	25
Power Supply		Indoor unit is powered by the outdoor unit	
Indoor Unit	MCA	A	1.0
	Fan Motor Full Load Amperage	A	0.76
	Fan Motor Output	W	56
	Airflow Rate at Cooling, Dry	CFM	379-613-710-932
	Airflow Rate at Cooling, Wet	CFM	341-552-639-839
	Airflow Rate at Heating, Dry	CFM	431-613-710-816
	Sound Pressure Level [Cooling]	dB[A]	34-42-49-53
	Sound Pressure Level [Heating]	dB[A]	34-42-49-50
	Drain Pipe Size	In. [mm]	5/8 [16]
	Coating on Heat Exchanger		—
	External Finish Color		White(Munsell 1.0Y 9.2/0.2)
	Unit Dimensions	W x D x H: In. [mm]	46-1/16 x 11-5/8 x 14-3/8 [1,170 x 295 x 365]
	Package Dimensions	W x D x H: In. [mm]	51 x 18-1/2 x 14-1/4 [1,300 x 470 x 360]
Unit Weight	Lbs. [kg]	45 [20]	
Package Weight	Lbs. [kg]	52 [23]	
Indoor Unit Operating Temperature Range	Cooling Intake Air Temp [Maximum / Minimum]*	°F	90 DB, 73 WB / 67 DB, 57 WB
	Heating Intake Air Temp [Maximum / Minimum]	°F	80 DB / 70 DB
Outdoor Unit	MCA	A	22.0
	MOCP	A	25
	Fan Motor Full Load Amperage	A	0.93
	Fan Motor Output	W	50
	External Finish Color		Munsell 3Y 7.8/1.1 1
	Unit Dimensions	W x D x H: In. [mm]	33-1/16 x 13 x 34-5/8 [840 x 330 x 880]
	Package Dimensions	W x D x H: In. [mm]	38-3/4 x 16-3/4 x 39 [980 x 420 x 990]
	Unit Weight	Lbs. [kg]	122 [55]
Package Weight	Lbs. [kg]	138 [63]	
Outdoor Unit Operating Temperature Range	Cooling Air Temp [Maximum / Minimum]*	°F	115 DB / 14 DB
	Cooling Thermal Lock-out / Re-start Temperatures**	°F	-4 / 0
	Heating Air Temp [Maximum / Minimum]	°F	75 DB, 67 WB / -4 DB, 60 WB
	Heating Thermal Lock-out / Re-start Temperatures**	°F	-14 / -4

**NOTES:**

AHRI Rated Conditions

(Rated data is determined at a fixed compressor speed)

<sup>1</sup>Cooling (Indoor // Outdoor)

°F 80 DB, 67 WB // 95 DB, 75 WB

<sup>2</sup>Heating at 47°F (Indoor // Outdoor)

°F 70 DB, 60 WB // 47 DB, 43 WB

<sup>3</sup>Heating at 17°F (Indoor // Outdoor)

°F 70 DB, 60 WB // 17 DB, 15 WB

Conditions

<sup>4</sup>Heating at 5°F (Indoor // Outdoor)

°F 70 DB, 60 WB // 5 DB, 4 WB

\*Indoor/Outdoor Unit Operating Temperature Range (Cooling Air Temp [Maximum / Minimum]):

• Applications should be restricted to comfort cooling only; equipment cooling applications are not recommended for low ambient temperature conditions.

\*\*Outdoor Unit Operating Temperature Range (Cooling Thermal Lock-out / Re-start Temperatures; Heating Thermal Lock-out / Re-start Temperatures):

• System cuts out in heating mode to avoid thermistor error and automatically restarts at these temperatures.

## SPECIFICATIONS: MSZ-GS30NA2 & MUZ-GS30NA2

Refrigerant	Type		R410A
Piping	Gas Pipe Size O.D. [Flared]	In.[mm]	5/8 [15.88]
	Liquid Pipe Size O.D. [Flared]	In.[mm]	1/4 [6.35]
	Maximum Piping Length	Ft. [m]	100 [30]
	Maximum Height Difference	Ft. [m]	50 [15]

**NOTES:**

AHRI Rated Conditions (Rated data is determined at a fixed compressor speed)

<sup>1</sup> Cooling (Indoor // Outdoor)	°F	80 DB, 67 WB // 95 DB, 75 WB
<sup>2</sup> Heating at 47°F (Indoor // Outdoor)	°F	70 DB, 60 WB // 47 DB, 43 WB
<sup>3</sup> Heating at 17°F (Indoor // Outdoor)	°F	70 DB, 60 WB // 17 DB, 15 WB

Conditions <sup>4</sup>Heating at 5°F (Indoor // Outdoor) °F 70 DB, 60 WB // 5 DB, 4 WB

\*Indoor/Outdoor Unit Operating Temperature Range (Cooling Air Temp [Maximum / Minimum]):

- Applications should be restricted to comfort cooling only; equipment cooling applications are not recommended for low ambient temperature conditions.

\*\*Outdoor Unit Operating Temperature Range (Cooling Thermal Lock-out / Re-start Temperatures; Heating Thermal Lock-out / Re-start Temperatures):

- System cuts out in heating mode to avoid thermistor error and automatically restarts at these temperatures.

## INDOOR UNIT ACCESSORIES: MSZ-GS30NA2

Control Interface	IT Extender	PAC-WHS01IE-E
	kumo station® for kumo cloud®	PAC-WHS01HC-E
	Procon BACnet® and Modbus® Interface	PAC-UKPRC001-CN-1
	System Control Interface	MAC-334IF-E
	Thermostat Interface	PAC-US445CN-1
	USNAP Adapter	PAC-WHS01UP-E
Remote Sensor	Wireless Interface for kumo cloud®	PAC-USWHS002-WF-2
	Wired Remote Sensor	M21EAA307
Wired Remote Controller	Wireless temperature and humidity sensor for kumo cloud®	PAC-USWHS003-TH-1
	Deluxe Wired MA Remote Controller†	PAR-40MAAU
	Simple Ductless Wired Remote Controller	PAC-SDW01RC-1
	Simple MA Remote Controller†	PAC-YT53CRAU-J
Wireless Remote Controller	Touch MA Controller†	PAR-CT01MAU-SB
	kumo touch™ RedLINK™ Wireless Controller	MHK2
Condensate	Lockdown bracket for remote controller	RCMKP1CB
	Blue Diamond (Advanced) Mini Condensate Pump w/ Reservoir & Sensor (208/230V) [recommended]	X87-721
	Blue Diamond (MegaBlue Advanced) Condensate Pump w/ Reservoir & Sensor	X87-835
	Blue Diamond Alarm Extension Cable — 6.5 Ft.	C13-192
	Blue Diamond MultiTank — collection tank for use with multiple pumps	C21-014
	Blue Diamond Sensor Extension Cable — 15 Ft.	C13-103
	Drain Pan Level Sensor/Control	SS610E
	Refco Condensate Pump (100-240 VAC)	GOBI-II
	Refco Condensate Pump (100-240 VAC) up to 120,000 BTU/H	COMBI
	Saueremann Condensate Pump	SI30-230
Disconnect Switch	(30A/600V/UL) [fits 2" X 4" utility box] - Black	TAZ-MS303
	(30A/600V/UL) [fits 2" X 4" utility box] - White	TAZ-MS303W
Lineset	100' x 1/4" x 100' x 5/8" Lineset (Twin-Tube Insulation)	MLS145812T-100
	15' x 1/4" x 15' x 5/8" Lineset (Twin-Tube Insulation)	MLS145812T-15
	30' x 1/4" x 30' x 5/8" Lineset (Twin-Tube Insulation)	MLS145812T-30
	50' x 1/4" x 50' x 5/8" Lineset (Twin-Tube Insulation)	MLS145812T-50
	65' x 1/4" x 65' x 5/8" Lineset (Twin-Tube Insulation)	MLS145812T-65

**NOTES:**

†Requires MAC-334IF-E

- M-Series EZ FIT® Recessed Ceiling Cassette, Floor-mount and Wall-mount  
Allows indoor units to connect to an MA Controller:
  - Deluxe MA Remote Controller
  - Simple MA Controller
  - Touch MA Controller

## OUTDOOR UNIT ACCESSORIES: MUZ-GS30NA2

Air Outlet Guide	Air Outlet Guide	MAC-890SG-E
Control/Service Tool	M- & P-Series Maintenance Tool Cable Set	M21EC0397
	Maintenance Tool Interface	PAC-USCMS-MN-1
Drain Socket	Drain Socket	MAC-871DS
Hail Guards	Hail Guard	HG-A7
Mini-Split Wire	14 Gauge, 4 wire MiniSplit Cable—250 ft. roll	SW144-250
	14 Gauge, 4 wire MiniSplit Cable—50 ft. roll	SW144-50
	16 Gauge, 4 wire MiniSplit Cable—250 ft. roll	SW164-250
	16 Gauge, 4 wire MiniSplit Cable—50 ft. roll	SW164-50
Mounting Pad	Condensing Unit Mounting Pad: 16" x 36" x 3"	ULTRILITE1
	Outdoor Unit 3-1/4 inch Mounting Base (Pair) - Plastic	DSD-400P
Stand	18" Single Fan Stand	QSMS1801M
	24" Single Fan Stand	QSMS2401M
	Condenser Wall Bracket	QSWB2000M-1
	Condenser Wall Bracket - Stainless Steel Finish	QSWBSS
	Outdoor Unit Stand — 12" High	QSMS1201M

# INDOOR UNIT DIMENSIONS: MSZ-GS30NA2

Unit : inch

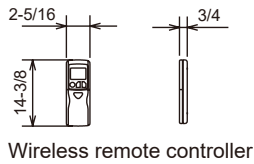
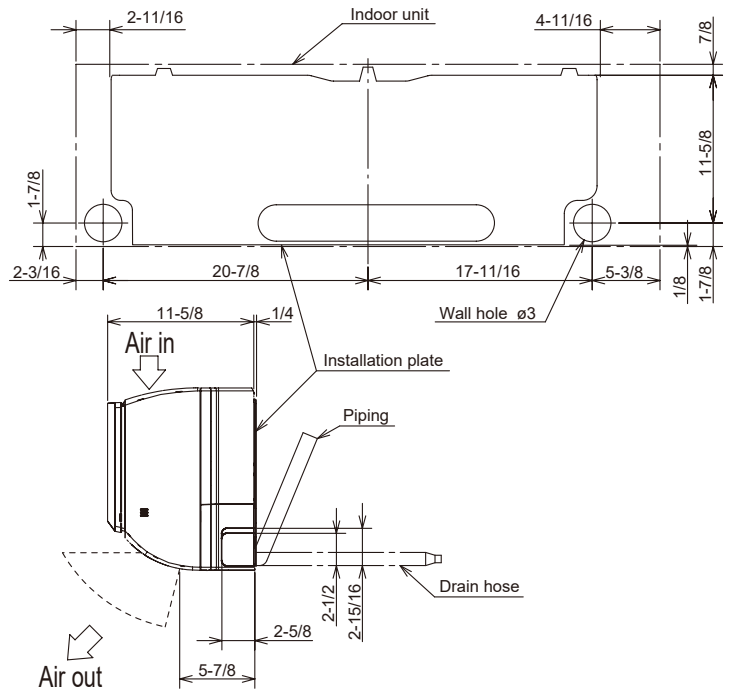
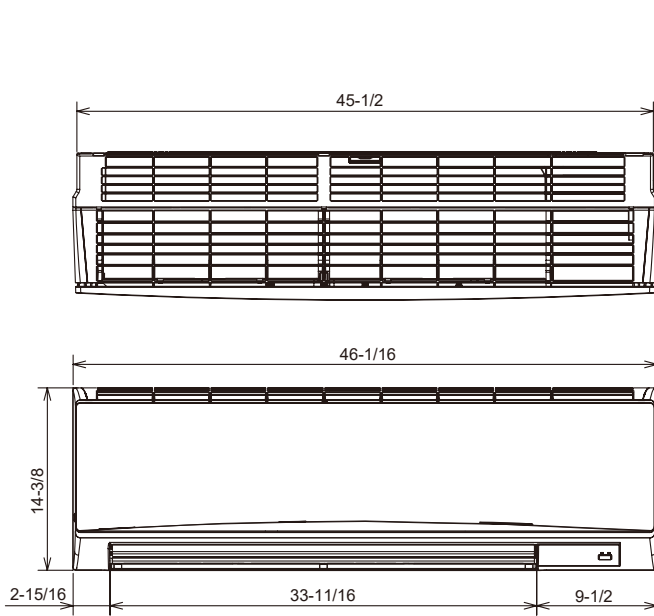

	PIPING	INSULATION
LIQUID LINE	$\phi 3/8 - 19 - 11/16$ (FLARED CONNECTION $\phi 1/4$ )	$\phi 1 - 1/4$ O.D $\phi 9/16$ I.D
GAS LINE	$\phi 15/32 - 17 - 13/16$ (FLARED CONNECTION $\phi 5/8$ )	$\phi 1 - 7/16$ O.D $\phi 13/16$ I.D
DRAIN HOSE	INSULATION $\phi 1 - 1/8$ CONNECTED PART $\phi 5/8$ O.D	

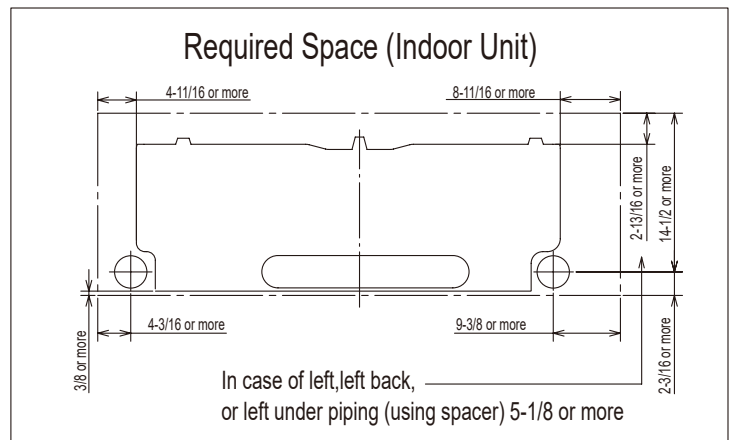

# OUTDOOR UNIT DIMENSIONS: MUZ-GS30NA2

Unit: inch

## REQUIRED SPACE

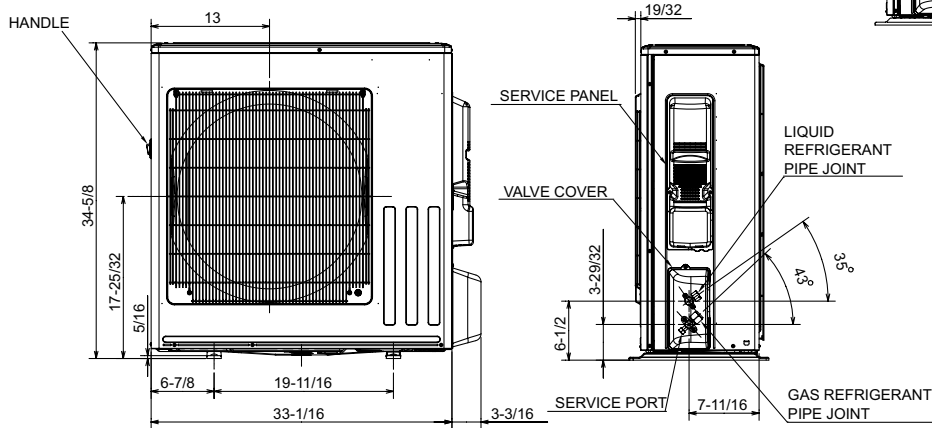
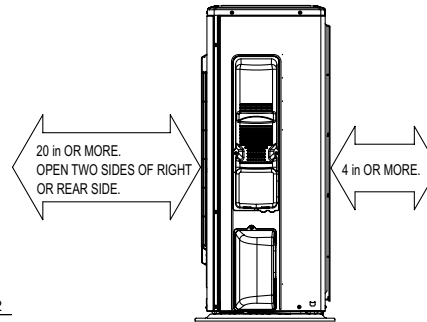
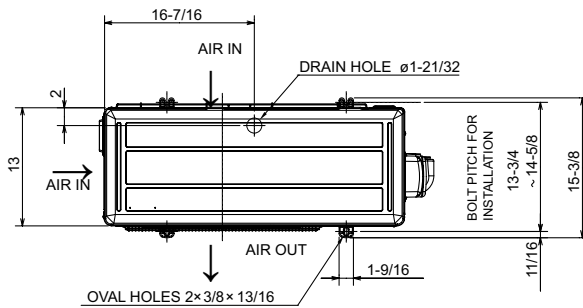
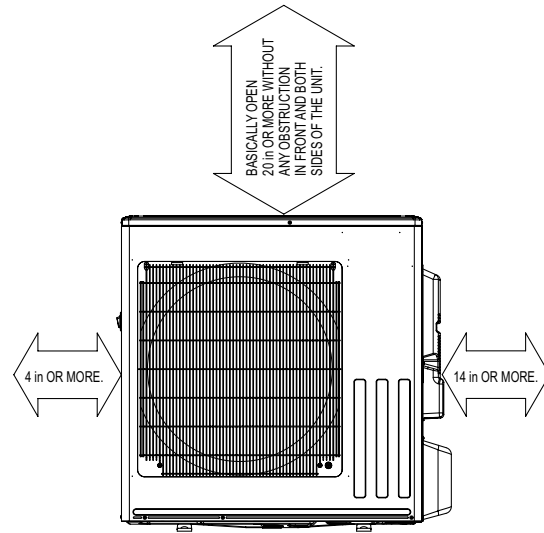

REFRIGERANT PIPE JOINT	LIQUID REFRIGERANT PPE	FLARED $\phi 6.35$ (1/4")
	GAS REFRIGERANT PPE	FLARED $\phi 15.88$ (5/8")

1340 Satellite Boulevard Suwanee, GA 30024  
Toll Free: 800-433-4822 www.mehvac.com

