



The new degree of comfort.™

Rheem *Classic*® Series Downflow Gas Furnace

R801T Downflow Series

80% A.F.U.E.†

Input Rates 50-125 kBTU



†A.F.U.E. (Annual Fuel Utilization Efficiency) calculated in accordance with Department of Energy test procedures.

- 80% residential Gas Furnace CSA certified
- PlusOne™ Diagnostics – 7 Segment LED all units
- PlusOne™ Ignition System – DSI for reliability and longevity
- Heat exchanger is removable for improved serviceability. Aluminized steel construction provides maximum corrosion resistance and thermal fatigue reliability.
- Low profile 34" cabinet ideal for space constrained installations
- Integrated Control board features dip switches for easy system set up
- QR code for quick access to product information from your smart phone or tablet
- Insulated blower compartment
- Constant Torque electrically commutated motor



TABLE OF CONTENTS

Standard & Optional Equipment	3
Model Features/Physical Data & Specifications	4
Model Number Identification	5
Dimensional Data.....	6
Blower Performance Data.....	7
Accessories.....	8
Limited Warranty	9

CONSTANT TORQUE ECM MOTOR

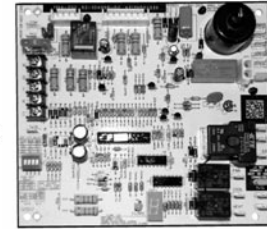

INTEGRATED FURNACE CONTROL

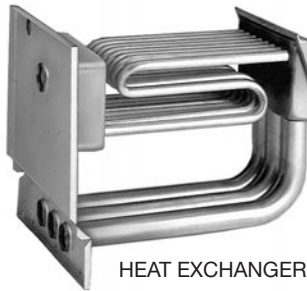

HEAT EXCHANGER

DRAFT INDUCER MOTOR

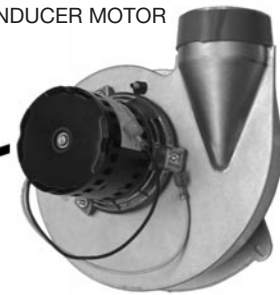

DIRECT SPARK IGNITOR WITH REMOTE SENSE



IN-SHOT BURNERS

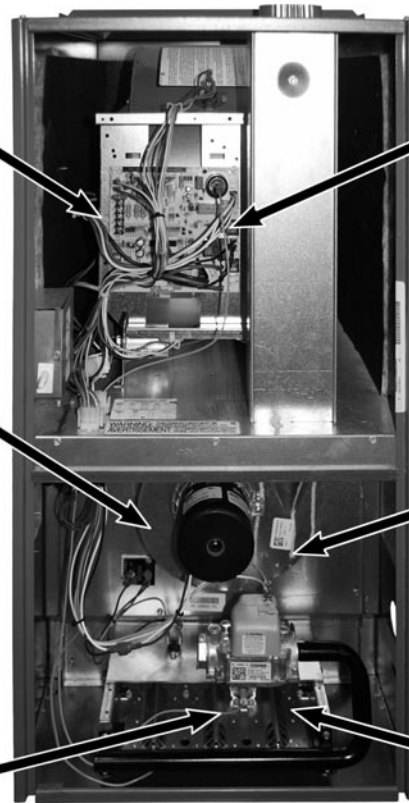
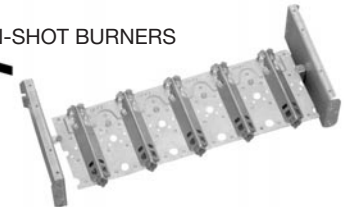

STANDARD EQUIPMENT

Completely assembled and wired; induced draft; pressure switch; redundant main gas control; blower compartment door safety switch; solid state time on/time off blower control; limit control; manual shut-off valve, pressure regulator for natural and L.P. (propane) gas; transformer; direct drive multi-speed blower motor. Furnaces are equipped with cooling/heating relay and transformer (40VA) ready for air conditioning applications. (Please note: a thermostat is not included as standard equipment.) Flame sensor diagnostics; on-board twinning; fused-protection (secondary), **3rd speed option for continuous fan; common heat/cool terminal.**

OPTIONAL EQUIPMENT

NOTE: Furnace is not listed for use with fuels other than natural or L.P. (propane) gas.

The complete terms of limited and other warranties are available at our sales office, or through local installer.

All models can be converted by a qualified Rheem distributor or local service dealer to use L.P. (propane) gas without changing burners. Factory approved kits must be used to convert from natural to L.P. (propane) gas and may be ordered as optional accessories from a Rheem parts distributor.

For L.P. (propane) operation, refer to Conversion Kit Index Form.

NOTE: For natural and L.P. (propane) gas models, direct spark ignition is 100% lockout type.

WARNING

THIS FURNACE IS NOT APPROVED
OR RECOMMENDED
FOR USE IN MOBILE HOMES



Model Features

- 80% residential Gas Furnace CSA certified
- PlusOne™ Diagnostics — 7 Segment LED all units
- PlusOne™ Ignition System – DSI for reliability and longevity
- Heat exchanger is removable for improved serviceability. Aluminized steel construction provides maximum corrosion resistance and thermal fatigue reliability.
- Low profile 34" cabinet ideal for space constrained installations
- Integrated Controls board features dip switches for easy system set up
- QR code for quick access to product information from your smart phone or tablet
- Insulated blower compartment
- Constant Torque electrically commutated motor

Physical Data and Specifications

U.S. and Canadian Models

MODEL NUMBERS R801T (DF) SERIES	R801TA050314Z*A	R801TB075317Z*B	R801TA075521Z*B	R801TA100521Z*B	R801TA125524Z*B
Input in BTU's/Hr [kW] ②	50,000 [15]	75,000 [22]	75,000 [22]	100,000 [29]	125,000 [37]
Heating Capacity in BTU's/Hr [kW] ①	40,000 [12]	60,000 [18]	60,000 [18]	80,000 [23]	103,000 [30]
Heat Ext. Static Pressure in "wc [kPa]	.10 [.025]	0.12 [0.029]	0.12 [0.029]	0.15 [0.037]	0.2 [0.05]
Blower (D x W) in inches [mm]	11 x 6 [279 x 152]	11 x 7 [279 x 178]	11 x 10 [279 x 254]	11 x 10 [279 x 254]	11 x 10 [279 x 254]
Motor H.P.-Speeds - Type [W]	1/2 hp [373] 5 Spd Constant Torque	1/2hp, 5spd, X-13 [373]	1hp, 5spd, X-13 [746]	1hp, 5spd, X-13 [746]	1hp, 5spd, X-13 [746]
Min. Circuit Ampacity	9	9	13	12	15
Min. Overload Protection	15	15	15	15	20
Max. Overload Protection	15	15	20	15	25
Heating Speed (factory setting)	MED-LOW	MED-HIGH	MED	MED-HIGH	MED-HIGH
Cooling Speed (factory setting)	HIGH	HIGH	HIGH	HIGH	HIGH
Cooling in CFM [L/s] @ 0.5"wc [0.12 kPa] E.S.P. (nominal)	1301 [614]	1200 [566]	2000 [944]	2000 [944]	2000 [944]
Rated E.S.P. in "wc [kPa]	0.5 [.12]	0.5 [0.12]	0.5 [0.12]	0.5 [0.12]	0.5 [0.12]
Temperature Rise Range in °F [°C]	25-55 [13.9-30.6]	35-65 [19.4-36.1]	25-55 [13.9-30.6]	30-60 [17-33]	35-65 [19.4-36.1]
Max Outlet Air in °F [°C]	155 [68.3]	190 [87.8]	165 [73.8]	190 [87.7]	185 [85.0]
Approx. Shipping Weight in Lbs. [kg]	85 [38.6]	105 [48]	120 [54]	120 [54]	140 [63]
AFUE - Electronic Ignition Modules ①	80%	80%	80%	80%	80%

NOTES: All models are 115V, 60HZ, 1Ø. Gas connection size for all models is 1/2" N.P.T.

① In accordance with D.O.E. test procedures.

② See Conversion Kit Index Form for high altitude derate in U.S. applications.

This furnace does not meet air district requirements of 14 ng/J NOx emissions limit, and thus is subject to a mitigation fee of up to \$450. This furnace is not eligible for the Clean Air Furnace Rebate Program: www.CleanAirFurnaceRebate.com.

This furnace is to be installed for propane firing only in air districts requiring 14 ng/J NOx emission limits. Operating in natural gas mode is in violation of these Rules.

[] Designates Metric Conversions





Air

Model Number Identification—Downflow Models

<u>R</u>	<u>80</u>	<u>1</u>	<u>T</u>	<u>A</u>	<u>075</u>	<u>4</u>	<u>17</u>	<u>Z</u>	<u>S</u>	<u>A</u>
Rheem	80 = 80% AFUE	1 = Single Stage	T = Constant Torque	Design Series A = 1st Design B = 2nd Design	Input BTU/HR [kW] 050 = 50,000 [15] 075 = 75,000 [22] 100 = 100,000 [29] 125 = 125,000 [37]	3 = Up to 3 Ton 4 = 2 1/2 to 4 Ton 5 = 3 1/2 to 5 Ton	Cabinet Width 14 = 14" 17 = 17.5" 21 = 21" 24 = 24.5"	Z = Down and Zero Clearance Downflow	X = Low NO _x S = Standard	Revision- Marketing A – First Time Release B – 2nd Design Series

[] Designates Metric Conversions



Downflow Dimensions

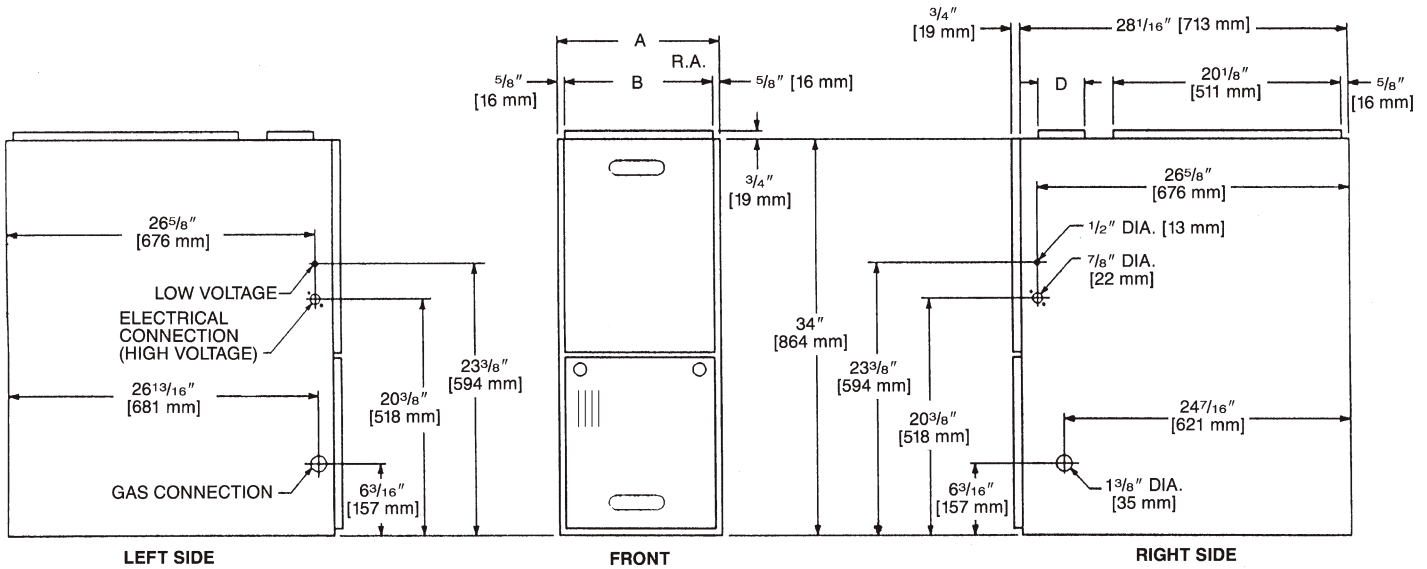
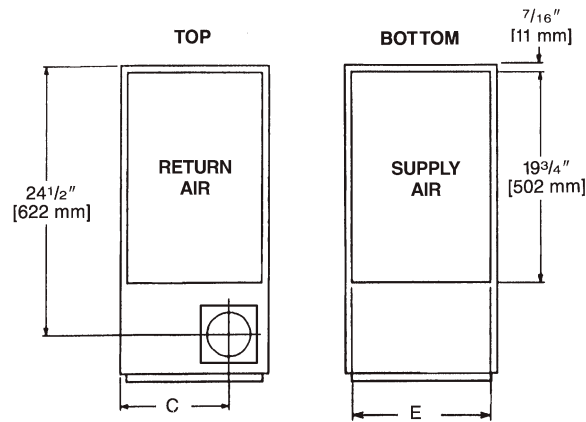

Dimensional Data

MODEL R801T (DOWNFLOW) SERIES	A	B	C	D	E	REDUCED CLEARANCES (IN.) [mm]						
						LEFT SIDE	RIGHT SIDE	BACK	TOP	FRONT	VENT	SHIP. WGTS. (LBS.) [kg]
050	14 [356]	12 ²⁷ / ₃₂ [326]	10 ³ / ₈ [264]	①	13 ¹ / ₈ [333]	0	4 ②	0	1 [25]	3 [76]	6 [152] ③	85 [38.6]
075317	17 1/2 [445]	16 ¹¹ / ₃₂ [415]	12 ¹ / ₈ [308]	①	16 ⁵ / ₈ [422]	0	3 ②	0	1 [25]	3 [76]	6 [152] ③	105 [47.6]
075521	21 [533]	19 ²⁷ / ₃₂ [504]	13 ⁷ / ₈ [352]	①	20 ¹ / ₈ [511]	0	0	0	1 [25]	3 [76]	6 [152] ③	120 [54.4]
100	21 [533]	19 ²⁷ / ₃₂ [504]	13 ⁷ / ₈ [352]	①	20 ¹ / ₈ [511]	0	0	0	1 [25]	3 [76]	6 [152] ③	120 [54.4]
125	24 1/2 [622]	23 ¹¹ / ₃₂ [593]	15 ⁵ / ₈ [397]	①	23 ⁵ / ₈ [600]	0	0	0	1 [25]	3 [76]	6 [152] ③	140 [63.5]

NOTES: ① May require a 3" [76 mm] to 4" [102 mm] or 3" [76 mm] to 5" [127 mm] adapter.

② May be 0" [0 mm] with type B vent.

③ May be 1" [25 mm] with type B vent.

Furnaces must be vented in accordance with the National Fuel Gas Code, ANSI Z223.1 and in accordance with local codes.

[] Designates Metric Conversions

**Blower Performance Data—Downflow Models**

AIR FLOW PERFORMANCE - (-)801T SERIES (Downflow) MODELS												
INPUT (Btu) CABINET WIDTH (in)	AIRFLOW CONTROL SETTINGS	SPEED TAP	CFM [L/s] AIR DELIVERY EXTERNAL STATIC PRESSURE INCHES WATER COLUMN [kPa]									
			0.1 [0.02]	0.2 [0.05]	0.3 [0.07]	0.4 [.10]	0.5 [0.12]	0.6 [0.15]	0.7 [0.17]	0.8 [.19]	0.9 [.22]	1.0 [.25]
			50k 14"	CIRC FAN	LOW	889	770	615	475	428	377	335
HEAT OR HEAT/COOL	MED. LO	1029		989	954	918	884	841	798	759	722	679
COOL	MEDIUM	1190		1155	1116	1083	1059	1032	1000	971	939	904
COOL	MED. HIGH	1364		1329	1310	1288	1264	1228	1205	1176	1155	1117
COOL	HIGH	1419		1395	1362	1336	1309	1298	1271	1249	1222	1192
75k 17"	CIRC FAN	LOW	940	812	673	619	566	508	457	403	362	326
	COOL	MED. LO	1013	968	916	875	824	772	729	683	642	605
	COOL	MEDIUM	1222	1184	1126	1089	1051	1016	971	939	897	864
	HEAT OR HEAT/COOL	MED. HIGH	1384	1348	1310	1269	1235	1206	1171	1139	1109	1076
	COOL	HIGH	1510	1471	1439	1407	1374	1342	1310	1285	1255	1213
75k 21"	CIRC FAN	LOW	1231	1108	1040	982	915	855	798	738	690	642
	COOL	MED. LO	1413	1346	1297	1242	1190	1141	1088	1039	992	939
	HEAT OR HEAT/COOL	MEDIUM	1616	1563	1516	1466	1425	1370	1327	1289	1245	1204
	COOL	MED. HIGH	1925	1879	1839	1798	1764	1721	1678	1639	1599	1569
	COOL	HIGH	2154	2117	2074	2041	2008	1969	1933	1881	1804	1715
100k 21"	CIRC FAN	LOW	1236	1117	1051	995	942	873	820	770	713	670
	COOL	MED. LO	1360	1300	1255	1203	1152	1101	1059	1011	954	924
	COOL	MEDIUM	1564	1516	1476	1433	1388	1345	1312	1267	1222	1187
	HEAT OR HEAT/COOL	MED. HIGH	1822	1786	1742	1703	1670	1629	1597	1556	1520	1485
	COOL	HIGH	1990	1949	1914	1877	1838	1802	1776	1741	1708	1661
125k 24"	CIRC FAN	LOW	1172	989	919	852	781	715	651	613	570	522
	COOL	MED. LO	1261	1199	1137	1072	1009	950	889	834	778	735
	COOL	MEDIUM	1519	1454	1398	1350	1295	1242	1190	1142	1097	1051
	HEAT OR HEAT/COOL	MED. HIGH	1817	1767	1722	1674	1622	1583	1544	1494	1467	1427
	COOL	HIGH	2391	2350	2299	2214	2151	2070	1990	1904	1787	1661

NOTE: Bold data is factory heating tap

[] Designates Metric Conversions

DOWNFLOW ACCESSORIES

DOWNFLOW WARNING: Unit design is certified for installation on non-combustible floor. A special factory supplied combustible floor sub-base is required when installing on a combustible floor. Failure to install the sub-base may result in fire, property damage and personal injury.

COMBUSTIBLE FLOOR BASE DIMENSIONS

COMBUSTIBLE FLOOR BASE	USE WITH FURNACE SIZES	A IN. [mm]	B IN. [mm]	C IN. [mm]
RXGC-B14	R801T050	14 ¹ / ₂ [368]	13 ¹ / ₄ [337]	11 ¹ / ₄ [286]
RXGC-B17	R801T075317	18 [457]	16 ³ / ₄ [425]	14 ³ / ₄ [451]
RXGC-B21	R801T100521, R801T075521	21 ¹ / ₂ [546]	20 ¹ / ₄ [514]	18 ¹ / ₄ [464]
RXGC-B24	R801T125	25 [635]	23 ³ / ₄ [603]	21 ³ / ₄ [552]

[] Designates Metric Conversions

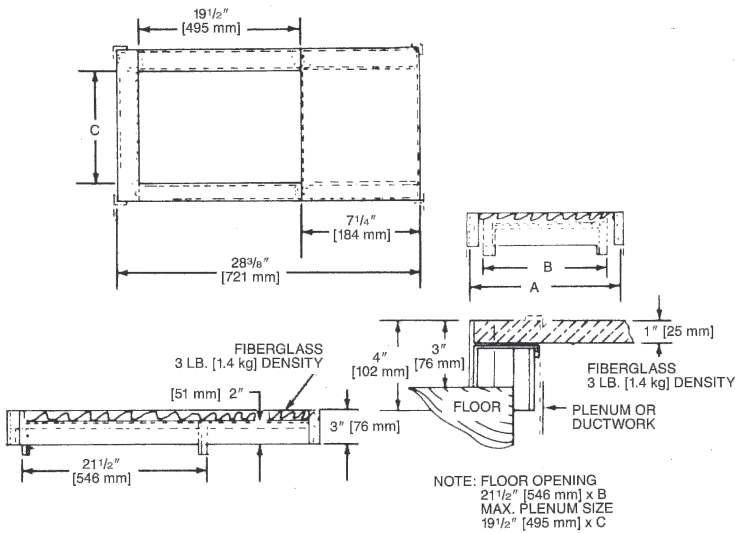

RXGF-CC*

FILTER RACK—Downflow top return mount. Requires (2) 14 x 20 Filters.

NOTE: Filter racks are shipped without filters.

*Filters available through PROSTOCK ®.

FOR HIGH ALTITUDES:

HIGH ALTITUDE OPTION CODE: U.S. & Canada –

None required for high altitudes.

HIGH ALTITUDE CONVERSION KITS: U.S. & Canada –

None required for high altitudes.

80+ HIGH ALTITUDE INSTRUCTIONS

Caution: Always follow National Fuel Gas Code (NFGC) guidelines when converting for high altitudes.

High altitude option codes are not required for these models. However, the burner orifice size needs to be recalculated and verified at elevations above 2000 ft. See Installation Instructions for more information.

NOTE: For Canadian installations only, an optional derate (manifold gas pressure reduction) method may be used to adjust the furnace for altitude. See Installation Instructions for more information. This optional method may **NOT** be used for U.S. installations.

GENERAL TERMS OF LIMITED WARRANTY*

Rheem will furnish a replacement for any part of this product which fails in normal use and service within the applicable period stated, in accordance with the terms of the limited warranty.

***For complete details of the Limited and Conditional Warranties, including applicable terms and conditions, contact your local contractor or the Manufacturer for a copy of the product warranty certificate.**

Heat Exchanger.....Twenty (20 Years)
Conditional Parts (Registration Required)Ten (10) Years



The new degree of comfort.™

In keeping with its policy of continuous progress and product improvement, Rheem reserves the right to make changes without notice.

Rheem Heating, Cooling & Water Heating • 5600 Old Greenwood Road
Fort Smith, Arkansas 72908 • www.rheem.com

Rheem Canada Ltd./Ltée • 125 Edgeware Road, Unit 1
Brampton, Ontario • L6Y 0P5



INTEGRATED HOME COMFORT

PRINTED IN U.S.A. 4/20 QG FORM NO. G11-549 REV. 5