



The new degree of comfort.®

Endeavor® Line *Classic Plus*® Series iM Heat Pumps



This product meets a stringent set of our internally defined sustainability standards



RP16AZ

Cooling Efficiencies up to: 17.0 SEER2/10.4 EER2

Heating Efficiency: 8.1 HSPF2

Nominal Sizes: 2 to 5 Ton [7.0 to 17.6 kW]

Cooling Capacities 22.8 to 55.0 kBTU [6.7 to 16.1 kW]



The Bluetooth® word mark and logos are registered trademarks owned by Bluetooth SIG, Inc. and any use of such marks by Rheem® is under license. Other trademarks and trade names are those of their respective owners.

Table of Contents

Features & Benefits	3
Model Number Identification	4
General Data/Electrical Data	5
Accessories	6
Unit Dimensions	7
Clearances	8
Refrigerant Line Size Information	9-10
Performance Data	11
Limited Warranty	12

Features and Benefits

- **EcoNet® Enabled:** Automatic system configuration and optimization
- **PlusOne® Diagnostics & Bluetooth®¹ Connectivity:** With the Rheem Contractor & EcoNet® Apps, built-in technology makes advanced set-up, monitoring, troubleshooting, and repairing the product easier than ever before
- **PlusOne® Variable Speed Twin Rotary Compressor & Inverter Drive:**
 - Features variable speed operation from 45 to 70% capacity, or 100% capacity via line voltage, with the EcoNet® Smart Thermostat
 - 3-speed operation when installed with a 24V two-stage thermostat
 - Provides precise temperature control, advanced humidity control and greater efficiency
- **Brushless DC Condenser Motors (BLDC):** Enhances reliability and allows for easier serviceability
- **Swept Wing Fan Technology:** Features quieter operation and improved unit acoustics
- **7 mm Condenser Copper Coil²:** Requires less refrigerant allowing for a smaller and lighter footprint while enhancing reliability
- **Inverted Reversing Valve:** Allows for faster heat transfer with gravity assist shifting and reduced joint stress for increased reliability
- **PlusOne® Expanded Valve Space:** 3 in. – 4 in. – 5 in. service valve space – provides a minimum working area of 27-square inches for easier access³
- **Triple Service Access:** 15 in. wide, industry leading access, two fastener, removeable corner and individual louver panels - makes repairs faster and easier

¹The Bluetooth® word mark and logos are registered trademarks owned by Bluetooth SIG, Inc. and any use of such marks by Rheem® is under license. Other trademarks and trade names are those of their respective owners.

²Does not apply to the 5 ton model.

³Does not apply to 2 or 3 ton models.

Heat Pumps

<u>R</u>	<u>P</u>	<u>16</u>	<u>A</u>	<u>Z</u>	<u>24</u>	<u>A</u>	<u>J</u>	<u>3</u>	<u>C</u>	<u>A</u>
Brand	Product Category	SEER2	Region	Refrigerant	Capacity	Major Series	Voltage	Type	Controls	Minor Series
R - Rheem	P - Heat Pump	16 - 16 SEER2	A - All Regions	Z - R-410A	24 - 24,000 [7.03 kW] 36 - 36,000 [10.55 kW] 48 - 48,000 [14.07 kW] 60 - 60,000 [17.58 kW]	A - 1st Design	J - 208/230/1/60	3 - 3+ Stage	C - Communicating	A - 1st Series

[] Designates Metric Conversions

AVAILABLE MODELS	DESCRIPTION
RP16AZ24AJ3CA	Endeavor® Line <i>Classic Plus</i> ® 2 ton 16 SEER2 Variable Speed iM Heat Pump-208/230/1/60
RP16AZ36AJ3CA	Endeavor® Line <i>Classic Plus</i> ® 3 ton 16 SEER2 Variable Speed iM Heat Pump-208/230/1/60
RP16AZ48AJ3CA	Endeavor® Line <i>Classic Plus</i> ® 4 ton 16 SEER2 Variable Speed iM Heat Pump-208/230/1/60
RP16AZ60AJ3CA	Endeavor® Line <i>Classic Plus</i> ® 5 ton 16 SEER2 Variable Speed iM Heat Pump-208/230/1/60

STANDARD EQUIPMENT
R-410A Refrigerant
Twin Rotary Compressor
Compressor Sound Blanket
Field Installed Filter Drier
Front Seating Service Valves
Internal Thermal Overload
Long Line capability
3-4-5 Expanded Valve Space
Composite Basepan
15" Access to Internal Components
Quick release louver panel design
No fasteners to remove along bottom
Optimized Venturi Airflow
Single row condenser coil
Powder coated paint
Rust resistant screws
QR code
External gauge ports
Service trays

General Data				
MODEL NO.	RP16AZ24AJ3	RP16AZ36AJ3	RP16AZ48AJ3	RP16AZ60AJ3
Nominal Tonnage	2	3	4	5
Valve Connections				
Liquid Line O.D. – in.	3/8	3/8	3/8	3/8
Suction Line O.D. – in.	3/4	3/4	7/8	7/8
Refrigerant (R410A) furnished oz.¹	118	135	164	256
Compressor Type	Twin Rotary			
Outdoor Coil				
Net face area – Outer Coil	14.4	19.8	19.8	24.2
Net face area – Inner Coil	—	—	—	—
Tube diameter – in.	0.276	0.276	0.276	0.276
Number of rows	1	1	1	1
Fins per inch	22	24	22	20
Outdoor Fan				
Diameter – in.	20	24	24	26
Number of blades	3	3	3	3
Motor hp	1/5	1/5	1/3	1/2
CFM	2754	4560	4567	5477
RPM	1075	1000	1000	925
Watts	165	277	252	283
Shipping weight – lbs.	188	205	210	314
Operating weight – lbs.	181	198	203	307

Electrical Data				
Line Voltage Data (Volts-Phase-Hz)	208/230-1-60	208/230-1-60	208/230-1-60	208/230-1-60
Maximum overcurrent protection (amps)²	20	35	40	50
Minimum circuit ampacity³	12	21	25	30
Compressor				
Rated load amps	9	13	18	22
Locked rotor amps	65	68	96	119

¹Refrigerant charge sufficient for 15 ft. length of refrigerant lines. For longer line set requirements see the installation instructions for information about set length and additional refrigerant charge required.

²HACR type circuit breaker or fuse.

³Refer to National Electrical Code manual to determine wire, fuse and disconnect size requirements.

Accessories

MODEL NO.		RP16AZ24AJ3	RP16AZ36AJ3	RP16AZ48AJ3	RP16AZ60AJ3
EcoNet® Smart Thermostat		RETST800SYS	RETST800SYS	RETST800SYS	RETST800SYS
Compressor crankcase heater*		N/A	N/A	N/A	N/A
Compressor sound cover		68-23427-27	68-23427-28	68-23427-29	68-23427-29
Low pressure control		47-103454-01	47-103454-01	47-103454-01	47-103454-01
High pressure control		47-103669-02	47-103669-02	47-103669-02	47-103669-02
Liquid Line Solenoid (24 VAC, 50/60 Hz)	Solenoid Valve	200RD2T3TVLC	200RD2T3TVLC	200RD2T3TVLC	200RD2T3TVLC
	Solenoid Coil	61-AMG24V	61-AMG24V	61-AMG24V	61-AMG24V
Liquid Line Solenoid (120/240 VAC, 50/60 Hz)	Solenoid Valve	200RD2T3TVLC	200RD2T3TVLC	200RD2T3TVLC	200RD2T3TVLC
	Solenoid Coil	61-AMG120/240V	61-AMG120/240V	61-AMG120/240V	61-AMG120/240V

Weighted Sound Power Level (dBA)

UNIT SIZE - VOLTAGE, SERIES	STANDARD RATING (dBA) HIGH STAGE LOW STAGE	TYPICAL OCTAVE BAND SPECTRUM (dBA WITHOUT TONE ADJUSTMENT)						
		125	250	500	1000	2000	4000	8000
RP16AZ24AJ3	72.2	43.5	56.5	63.9	61.4	59.0	58.3	47.9
	63.6	37.8	48.9	55.4	52.7	49.9	51.6	42.4
RP16AZ36AJ3	72.9	49.2	60.5	64.7	60.2	61.3	59.2	46.6
	59.9	35.8	44.8	51.6	49.6	46.9	45.4	42.2
RP16AZ48AJ3	74.3	46.6	58.0	64.2	61.6	60.1	61.3	49.9
	61.5	35.1	46.0	53.8	47.9	46.4	53.5	42.0
RP16AZ60AJ3	71.2	45.7	56.0	63.5	59.7	57.4	54.6	47.9
	61.8	30.9	45.2	52.6	48.6	50.3	49.2	42.1

NOTE: Tested in accordance with AHRI Standard 270-08 (not listed in AHRI)

Unit Dimensions

MODEL NO.	OPERATING						SHIPPING					
	H (Height)		L (Length)		W (Width)		H (Height)		L (Length)		W (Width)	
	INCHES	mm	INCHES	mm	INCHES	mm	INCHES	mm	INCHES	mm	INCHES	mm
RP16AZ24AJ3CA	27.00	685.80	29.75	755.65	29.75	755.65	28.50	723.90	32.38	822.45	32.38	822.45
RP16AZ36AJ3CA	35.00	889.00	33.75	857.25	33.75	857.25	36.50	927.10	36.38	924.05	36.38	924.05
RP16AZ48AJ3CA	35.00	889.00	33.75	857.25	33.75	857.25	36.50	927.10	36.38	924.05	36.38	924.05
RP16AZ60AJ3CA	45.00	1143.00	35.75	908.05	35.75	908.05	46.50	1181.10	38.38	974.85	38.38	974.85

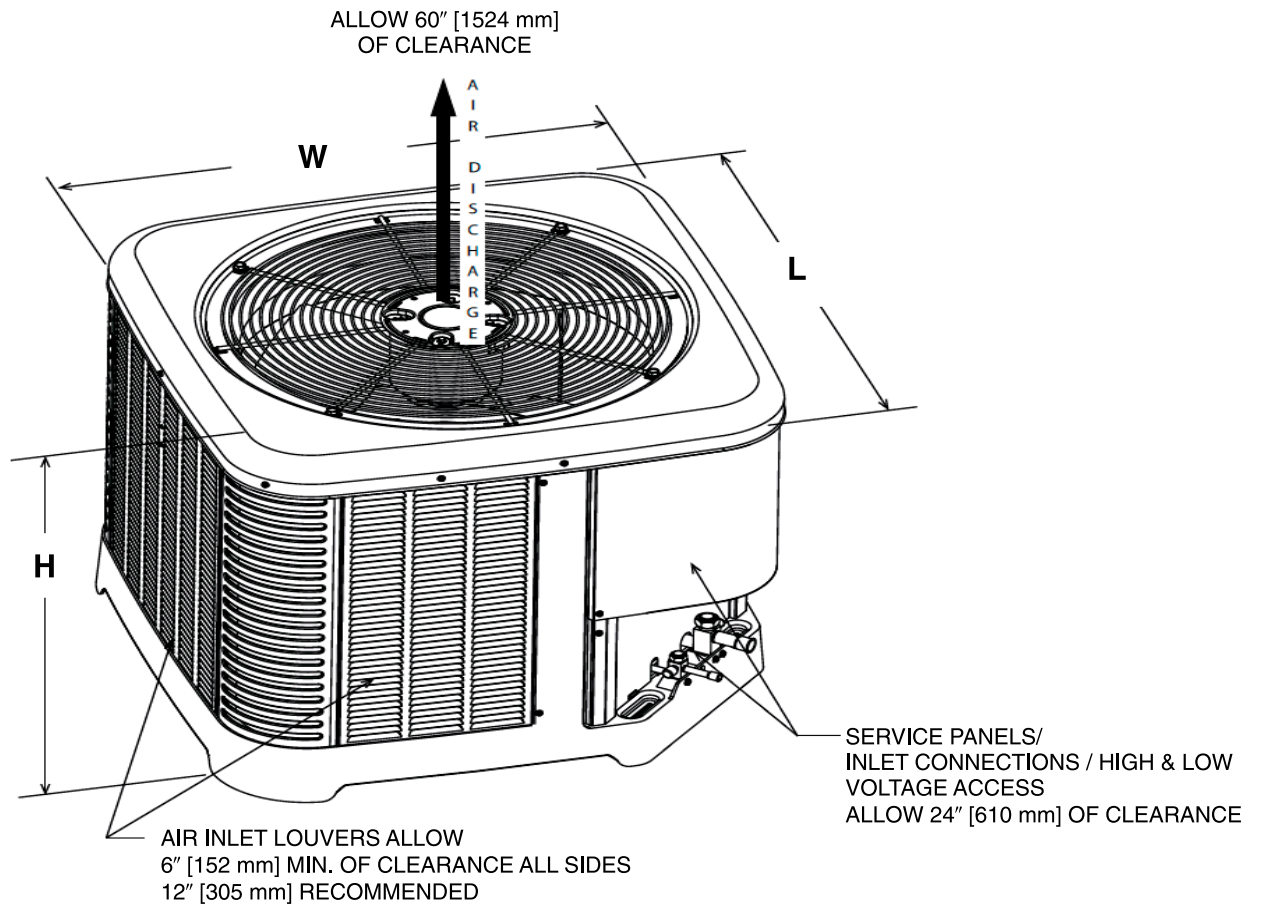

[] Designates Metric Conversions

ST-A1226-02-00

CLEARANCES

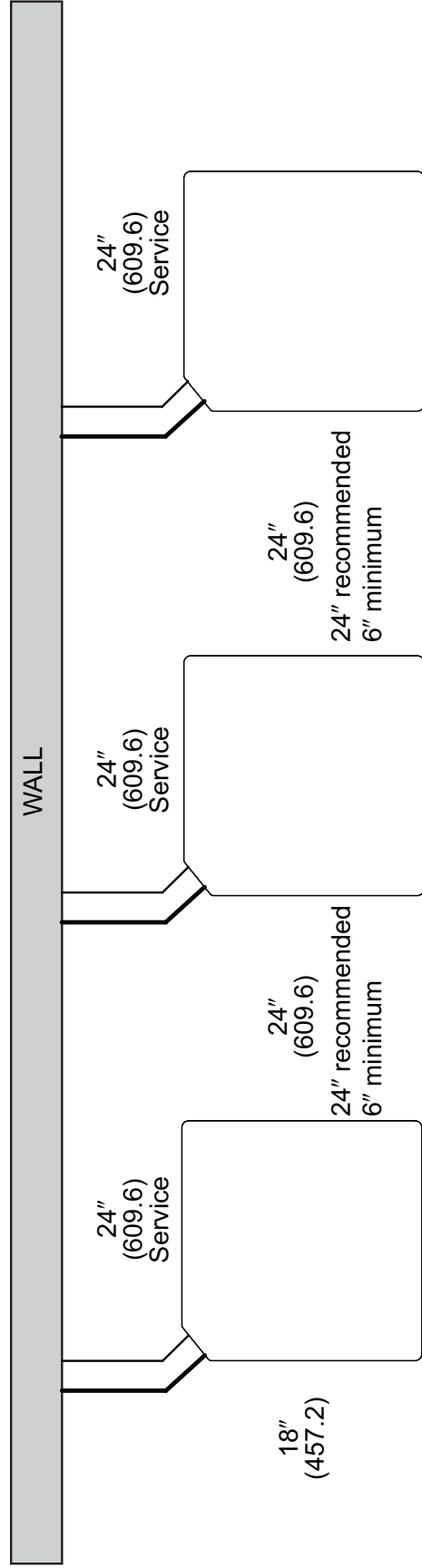
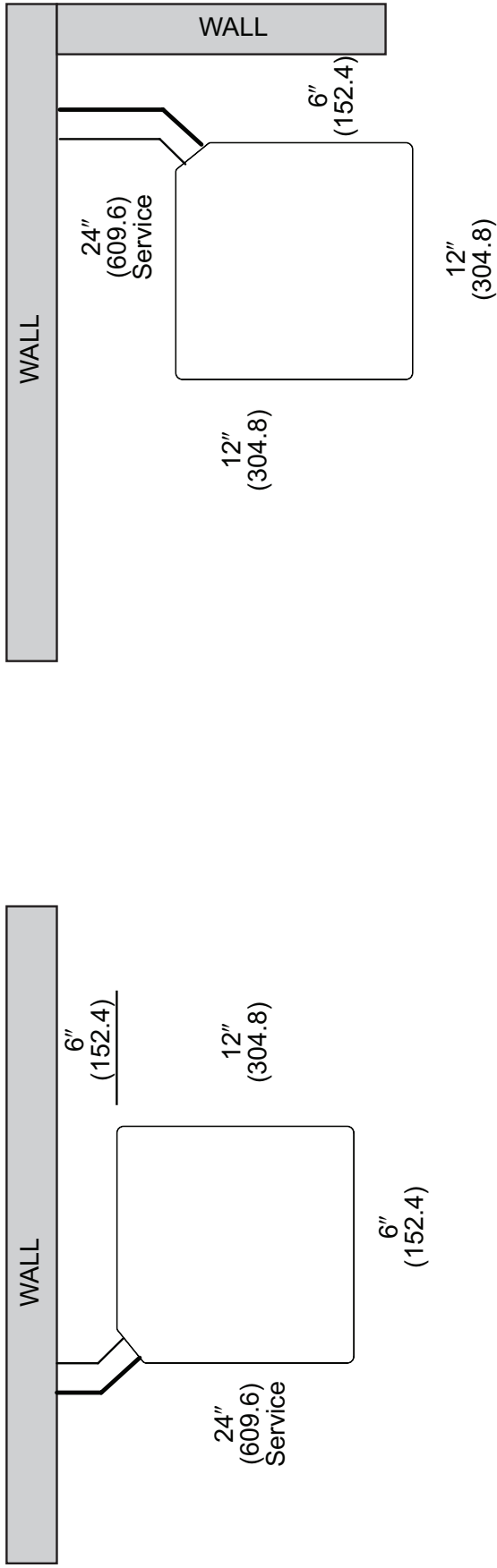

NOTE: NUMBERS IN () = mm

IMPORTANT: When installing multiple units in an alcove, roof well or partially enclosed area, ensure there is adequate ventilation to prevent re-circulation of discharge air.

Refrigerant Line Size Information

16 SEER2 VARIABLE SPEED HEAT PUMPS								
UNIT SIZE	ALLOWABLE LIQUID LINE SIZE	ALLOWABLE VAPOR LINE SIZE	OUTDOOR UNIT ABOVE OR BELOW INDOOR UNIT EQUIVALENT LENGTH (FEET)					
			< 25	26-50	51-75	76-100	101-125	126-150
			MAXIMUM VERTICAL SEPARATION/CAPACITY MULTIPLIER					
2.0 TON *SEE NOTE 3	1/4"	5/8"	25/1.00	50/0.99	33/0.98	60/0.97	NR	NR
	5/16"	5/8"	25/1.00	50/0.99	50/0.98	50/0.97	50/0.96	50/0.95
	3/8"	5/8"	25/1.00	50/0.99	50/0.98	50/0.97	50/0.96	50/0.95
	1/4"	3/4"	25/1.00	50/1.00	33/0.99	60/0.99	NR	NR
	5/16"	3/4"	25/1.00	50/1.00	50/0.99	50/0.99	50/0.99	50/0.98
	3/8"	3/4"	25/1.00	50/1.00	50/0.99	50/0.99	50/0.99	50/0.98
3 TON	5/16"	5/8"	25/0.99	50/0.97	50/0.95	50/0.93	36/0.91	NR
	3/8"	5/8"	25/0.99	50/0.97	50/0.95	50/0.93	50/0.91	NR
	5/16"	3/4"	25/1.00	50/0.99	50/0.99	50/0.98	36/0.97	20/0.96
	3/8"	3/4"	25/1.00	50/0.99	50/0.99	50/0.98	50/0.97	50/0.96
	1/2"	3/4"	25/1.00	50/0.99	50/0.99	50/0.98	50/0.97	50/0.96
4 TON	3/8"	3/4"	25/0.99	50/0.98	50/0.96	50/0.95	50/0.93	50/0.92
	1/2"	3/4"	25/0.99	50/0.98	50/0.96	50/0.95	50/0.93	50/0.92
	3/8"	7/8"	25/1.00	50/0.99	50/0.99	50/0.98	50/0.98	50/0.97
	1/2"	7/8"	25/1.00	50/0.99	50/0.99	50/0.98	50/0.98	50/0.97
5 TON	3/8"	3/4"	25/0.98	50/0.97	50/0.95	50/0.93	46/0.91	NR
	1/2"	3/4"	25/0.98	50/0.97	50/0.95	50/0.93	50/0.91	NR
	3/8"	7/8"	25/0.99	50/0.99	50/0.98	50/0.97	50/0.96	38/0.95
	1/2"	7/8"	25/0.99	50/0.99	50/0.98	50/0.97	50/0.96	50/0.95
	3/8"	1-1/8"	25/1.00	50/1.00	50/1.00	50/0.99	50/0.99	38/0.99
	1/2"	1-1/8"	25/1.00	50/1.00	50/1.00	50/0.99	50/0.99	50/0.99

NOTES:

- Do not exceed 150 ft. linear line length.
- Do not exceed 50 ft. vertical separation between indoor and outdoor units.
- *3/4" vapor line should only be used for 2 ton systems if outdoor unit is below or at same level as indoor unit to assure proper oil return.
- **1-1/8" vapor line should only be used for 5 ton systems if outdoor unit is below or at same level as indoor unit to assure proper oil return.
- Always use the smallest liquid line allowable to minimize refrigerant charge.
- Applications shaded in light gray indicate capacity multipliers between 0.90 and 0.96 which are not recommended, but are allowed.
- Applications shaded in dark gray are not recommended due to excessive liquid or suction pressure drop.
- Some longer lineset installations will require additional POE oil to be added to the system. See table below for additional oil volume requirements.**

ADDITIONAL POE OIL, Oz.											
LINESET LENGTH, FT	50	60	70	80	90	100	110	120	130	140	150
2T	N/A	1	3	4	5	7	8	9	11	12	13
3T	N/A	N/A	N/A	N/A	1	2	3	5	6	7	9
4T	N/A	N/A	N/A	N/A	N/A	N/A	N/A	N/A	N/A	0	1
5T	2	3	4	6	7	8	10	11	12	14	15

Refrigerant Line Size Information (Con't.)

16 SEER2 VARIABLE SPEED HEAT PUMPS								
UNIT SIZE	ALLOWABLE LIQUID LINE SIZE	ALLOWABLE VAPOR LINE SIZE	OUTDOOR UNIT ABOVE OR BELOW INDOOR UNIT EQUIVALENT LENGTH (METERS)					
			< 8	9-15	16-23	24-30	31-38	39-46
			MAXIMUM VERTICAL SEPARATION/CAPACITY MULTIPLIER					
7.0 kW [2.0 TON] *SEE NOTE 3	6.35 [1/4]	15.88 [5/8]	8/1.00	15/0.99	10/0.98	20/0.97	NR	NR
	7.94 [5/16]	15.88 [5/8]	8/1.00	15/0.99	15/0.98	15/0.97	15/0.96	15/0.95
	9.53 [3/8]	15.88 [5/8]	8/1.00	15/0.99	15/0.98	15/0.97	15/0.96	15/0.95
	6.35 [1/4]	19.05 [3/4]	8/1.00	15/0.99	10/0.99	20/0.99	NR	NR
	7.94 [5/16]	19.05 [3/4]	8/1.00	15/0.99	15/0.99	15/0.99	15/0.99	15/0.98
	9.53 [3/8]	19.05 [3/4]	8/1.00	15/0.99	15/0.99	15/0.99	15/0.99	15/0.98
10.6 kW [3 TON]	7.94 [5/16]	15.88 [5/8]	8/0.99	15/0.97	15/0.95	15/0.93	11/0.91	NR
	9.53 [3/8]	15.88 [5/8]	8/0.99	15/0.97	15/0.95	15/0.93	15/0.91	NR
	7.94 [5/16]	19.05 [3/4]	8/1.00	15/0.99	15/0.99	15/0.98	11/0.97	6/0.96
	9.53 [3/8]	19.05 [3/4]	8/1.00	15/0.99	15/0.99	15/0.98	15/0.97	15/0.96
	12.70 [1/2]	19.05 [3/4]	8/1.00	15/0.99	15/0.99	15/0.98	15/0.97	15/0.96
14.1 kW [4 TON]	9.53 [3/8]	19.05 [3/4]	8/0.99	15/0.98	15/0.96	15/0.95	15/0.93	15/0.92
	12.70 [1/2]	19.05 [3/4]	8/0.99	15/0.98	15/0.96	15/0.95	15/0.93	15/0.92
	9.53 [3/8]	22.23 [7/8]	8/1.00	15/0.99	15/0.99	15/0.98	15/0.98	15/0.97
	12.70 [1/2]	22.23 [7/8]	8/1.00	15/0.99	15/0.99	15/0.98	15/0.98	15/0.97
17.6 kW [5 TON]	9.53 [3/8]	19.05 [3/4]	8/0.98	15/0.97	15/0.95	15/0.93	14/0.91	NR
	12.70 [1/2]	19.05 [3/4]	8/0.98	15/0.97	15/0.95	15/0.93	15/0.91	NR
	9.53 [3/8]	22.23 [7/8]	8/0.99	15/0.99	15/0.98	15/0.97	15/0.96	12/0.95
	12.70 [1/2]	22.23 [7/8]	8/0.99	15/0.99	15/0.98	15/0.97	15/0.96	15/0.95
	9.53 [3/8]	28.58 [1-1/8]**	8/1.00	36540	36540	15/0.99	15/0.99	12/0.99
	12.70 [1/2]	28.58 [1-1/8]**	8/1.00	36540	36540	15/0.99	15/0.99	15/0.99

- NOTES:**
- 1) Do not exceed 46 meters linear line length.
 - 2) Do not exceed 15 meters vertical separation between indoor and outdoor units.
 - 3) *19.05 mm [3/4 in.] vapor line should only be used for 2 ton systems if outdoor unit is below or at same level as indoor unit to assure proper oil return.
 - 4) **28.58 mm [1-1/8 in.] vapor line should only be used for 5 ton systems if outdoor unit is below or at same level as indoor unit to assure proper oil return.
 - 5) Always use the smallest liquid line allowable to minimize refrigerant charge.
 - 6) Applications shaded in light gray indicate capacity multipliers between 0.90 and 0.96 which are not recommended, but are allowed.
 - 7) Applications shaded in dark gray are not recommended due to excessive liquid or suction pressure drop.
 - 8) **Some longer lineset installations will require additional POE oil to be added to the system. See table below for additional oil volume requirements.**

ADDITIONAL POE OIL, Oz.											
LINESET LENGTH, M	15.2	18.3	21.3	24.4	27.4	30.5	33.5	36.6	39.6	42.7	45.7
2T	N/A	1	3	4	5	7	8	9	11	12	13
3T	N/A	N/A	N/A	N/A	1	2	3	5	6	7	9
4T	N/A	N/A	N/A	N/A	N/A	N/A	N/A	N/A	N/A	0	1
5T	2	3	4	6	7	8	10	11	12	14	15

Performance Data @ AHRI Standard Conditions – Cooling

DESIGNATED TESTED COMBINATION (DTC)												
OUTDOOR UNIT	AIR HANDLER	TOTAL CAPACITY BTU/H [KW]	NET SENSIBLE BTU/H [KW]	NET LATENT BTU/H [KW]	SEER2	EER2	INDOOR CFM [L/S]	47 DEGREE HEATING CAPACITY BTU/H [KW]	47 DEGREE COP	17 DEGREE HEATING CAPACITY BTU/H [KW]	17 DEGREE COP	REGION IV HSPF2
RP16AZ24AJ3	RH3VZ2417STACN	22,600 [6.6]	17,300 [5.1]	5,300 [1.6]	16.0	9.8	750 [354.0]	22,800 [6.7]	3.50	13,800 [4.0]	2.40	8.0
RP16AZ36AJ3	RH3VZ3617STACN	34,200 [10.0]	26,200 [7.7]	8,000 [2.3]	16.0	9.8	1,100 [519.1]	34,500 [10.1]	3.20	21,600 [6.3]	2.30	7.5
RP16AZ48AJ3	RH3VZ4821STACN	45,500 [13.3]	34,900 [10.2]	10,600 [3.1]	16.0	9.8	1,475 [696.1]	45,500 [13.3]	3.40	28,500 [8.4]	2.40	8.0
RP16AZ60AJ3	RH3VZ6024STACN	55,000 [16.1]	42,200 [12.4]	12,800 [3.8]	16.0	9.8	1,725 [814.1]	57,000 [16.7]	3.20	35,500 [10.4]	2.40	8.0

NOTE: This data includes DTC (Designated Test Combination) ratings and is for reference purposes only. A full listing of official ratings and system match-ups, along with downloadable certificates, can be accessed from the AHRI website: www.ahridirectory.org.

[] Designates Metric Conversions



The new degree of comfort®

GENERAL TERMS OF LIMITED WARRANTY*

Rheem will furnish a replacement for any part of this product which fails in normal use and service within the applicable period stated, in accordance with the terms of the limited warranty.

Conditional Unit Replacement
(Registration Required)..... Ten (10) Years
Parts Ten (10) Years

***For complete details of the Limited and Conditional Warranties, including applicable terms and conditions, contact your local contractor or the Manufacturer for a copy of the product warranty certificate.**

Before proceeding with installation, refer to installation instructions packaged with each model, as well as complying with all Federal, State, Provincial, and Local codes, regulations, and practices.

© 2023 Rheem Manufacturing Company. Rheem trademarks owned by Rheem Manufacturing Company.

In keeping with its policy of continuous progress and product improvement, Rheem reserves the right to make changes without notice.

5600 Old Greenwood Road
Fort Smith, Arkansas 72908 • www.rheem.com

125 Edgeware Road, Unit 1
Brampton, Ontario • L6Y 0P5 • rheem.ca